



FORTUNE

福 斯 达 空 分

FORTUNE AIR SEPARATION PLANT

History

■1984: The predecessor of Hangzhou Fortune Gas Equipment Co., Ltd – ‘Yuhang Oxygen Generator Factory’ was established.

■1993: The first small size air separation plant of our company was manufactured and erected.

■1999: After reform, our company successfully changed from a state-owned company into a private one. In the year of 2000, our company changed the name, and Hangzhou Fortune Gas Equipment Co., Ltd was established.

■2000: The first low pressure small size air separation plant in our company was designed and manufactured.

■2002: ISO9001:2000 certified, and began to maintain a stringent quality assurance.

■2004: Started the cooperation with Cosmodyne LLC (USA), for LIQUID PLANT and LNG PLANT.

■2005: With the development, ‘Zhejiang Fortune Gas Equipment Co., Ltd.’ was established.

■2006: Started the cooperation with Cryonorm Projects, for entering European market with CE/PED and ASME standards.

■ 2006: Started to cooperate with Linde, Supplying Air Separation Plants for LINDE Gas and BOC.



Business Scope

- **Low pressure process Air Separation Plants.**
- **Full Liquid Air Separation Plants.**
- **High purity Nitrogen generator plants.**
- **Oxygen and Nitrogen liquefaction Plants.**
- **LNG plants.**
- **Acetylene plants.**
- **CO₂ purification & liquefaction Plants.**
- **Cryogenic liquid vaporizers.**
- **Cryogenic liquid storage tanks.**
- **Cryogenic liquid pumps.**
- **Vacuum Pipes.**
- **Technical training and service.**



Position in China

- The **first** private company who entered the air separation plant field.
- One of the **earliest** low pressure air separation plant manufacturers.
- The **first** private company who manufactured full liquid air separation plants
- Holding the **biggest** market share for small and medium size air separation plants in China's domestic market.
- The **only** company who has cooperators both from U.S.A and Europe.
- The **exclusive** cooperator of Linde in China.
- Enjoying **high reputation** not only from customers, sub-suppliers, but also from competitors.



Certificates

■ ISO 9001:2000



■ D1, D2 Pressure vessel design and manufacture license.

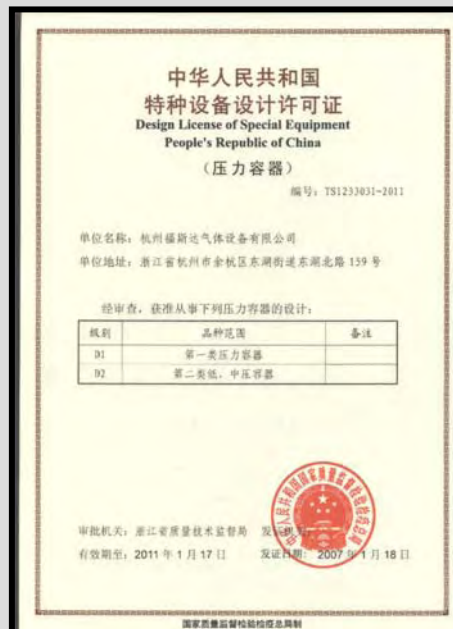

*Certificates
are
applying*



■ A2 license

- The third stage of medium and low pressure vessel manufacture license

■ C2 license

- Semi-trailer for liquid gases transportation manufacture license

■ C3 license

- Containerize liquid gases storage tank manufacture license

■ Studying and practicing ASME standard.

- We are designing and manufacturing one plant for Egypt as per ASME standard with 'U' stamp.

- We are applying for ASME certificate.

■ Studying and practicing CE standard.

- we are going to design and manufacture one GOX plant for European market as per CE/PED.

**Fortune's
TRDC
since 2002**



■ We established Technology Research and Developing Center in 2002.

■ Rewarded as Hangzhou High-Tech Development Center in 2005.

■ 7 times of Provincial new product rewards.

■ Provincial High-Tech company (2005)



Factory introduction



- More than 26,000 m² for whole factory at the first phase investment.
- Over 12,000 m² for workshop.
- On planning for second phase investment.
- Manufacture pressure vessels over 5000t yearly.
- Face main road, near to The Great Cannel, convenient for transportation.



Factory introduction



- What are inside the workshop:
 - 7 sets cranes, the Max lifting capacity of cranes is 50t.
 - Automatic submerged arc welding control centers.
 - MIG/MAG welding machines.
 - TIG welding machines.
 - RT, UT, MT, PT inspections
 - Vacuumize systems and vacuum inspection system.
 - Machining equipments.
 - 3 sets lapping machines, the Max operating capacity is 30 X 2500mm.
 - Surface treatment system and coating ejector.
 - Chemical analysis & mechanical property testing system
 - Others auxiliary equipments.

Factory introduction

■ Second Phase of Investment



■ A planned port will be available in near future.

■ The total area of port will be over than 20,000 m². It can park 500 to 1000 ton ship, will includes two sets of 100 ton cranes and two sets of 50 ton cranes.

■ Concerning about the cooperation between Fortune Gas and Linde, local government had set aside another piece of land which over than 68,000 m² beside the port for workshop extension.



Technical communication

■ With Linde



Technical communication

■ With Cosmodyne and CP



Design

■ 3D software design

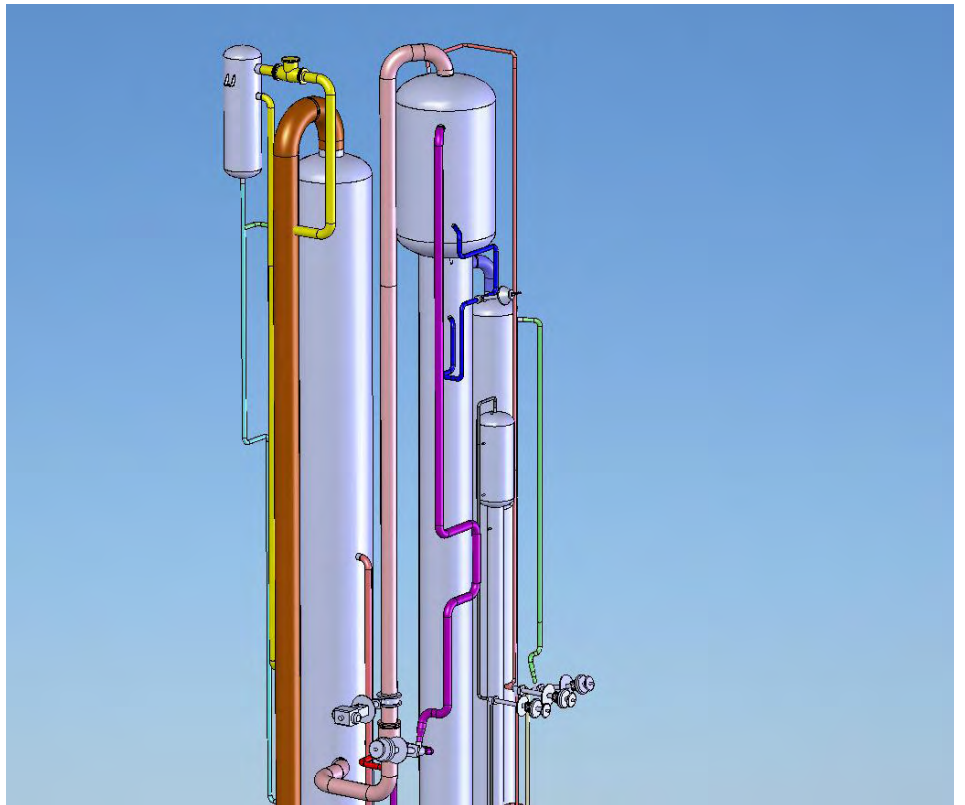
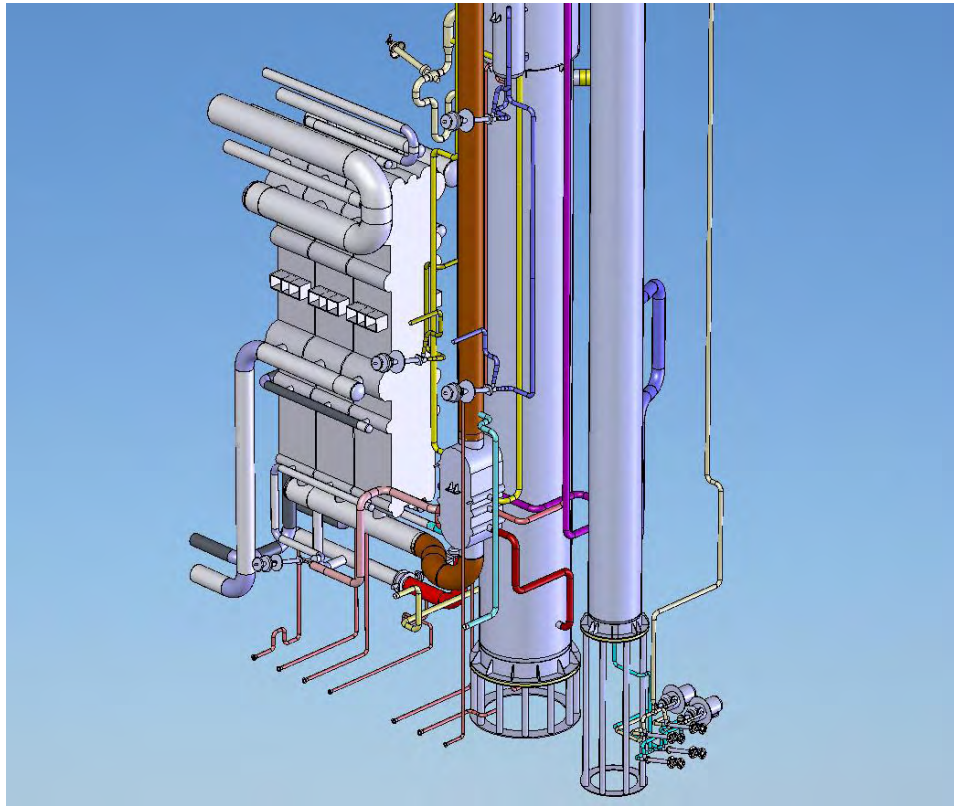

FORTUNE

Manufacture

■ Fractionation Column

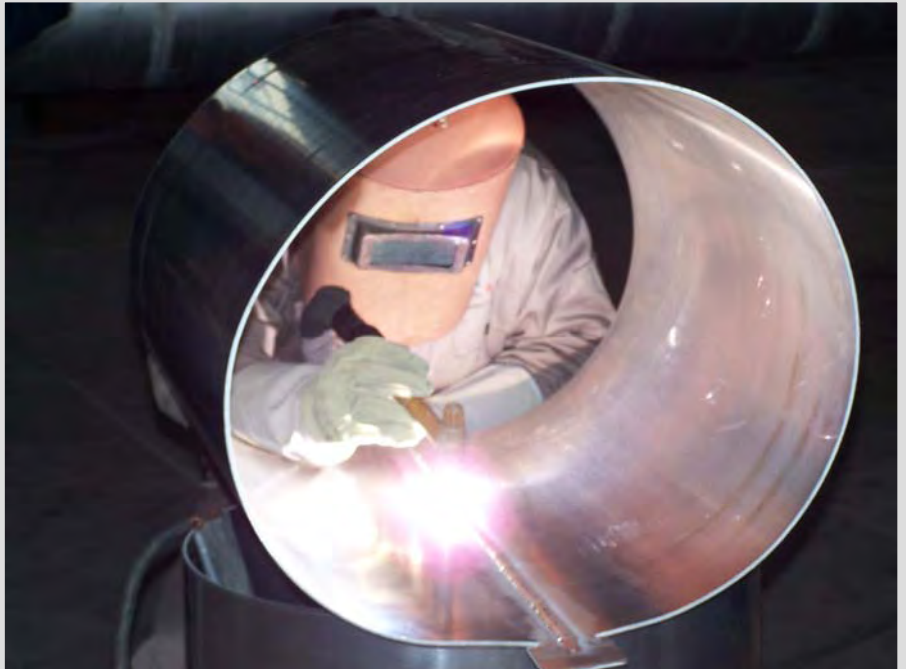

Manufacture

■ Pressure vessels



Manufacture

■ Cold Box Frame



Manufacture

■ Cold Box inside assembling

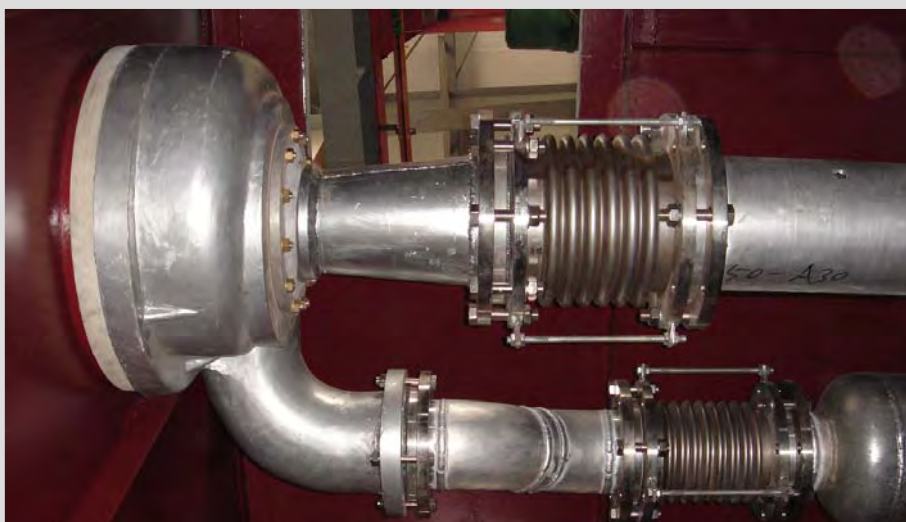

Delivery

■ Cold box one pc or separated delivery



Quality Control

Stress analyzer in design

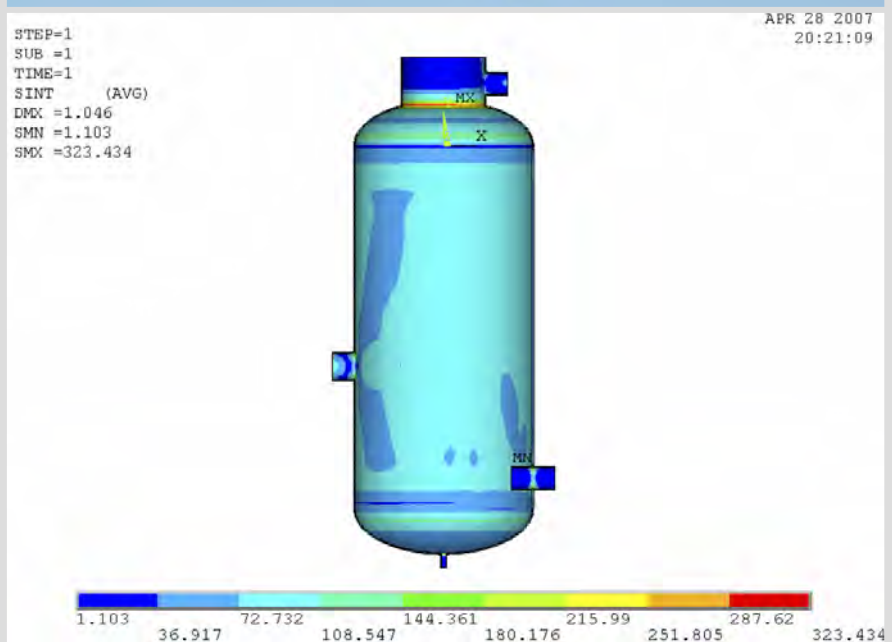
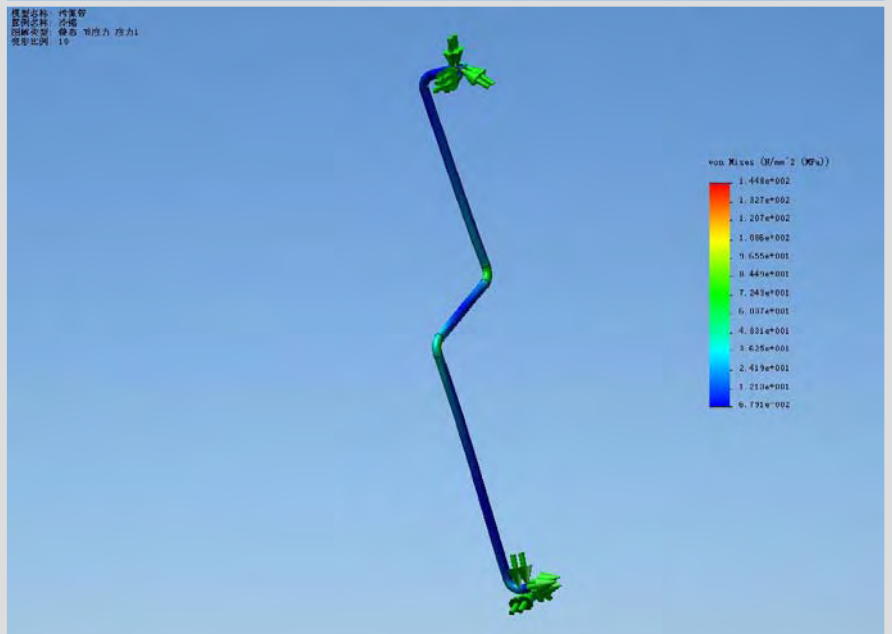
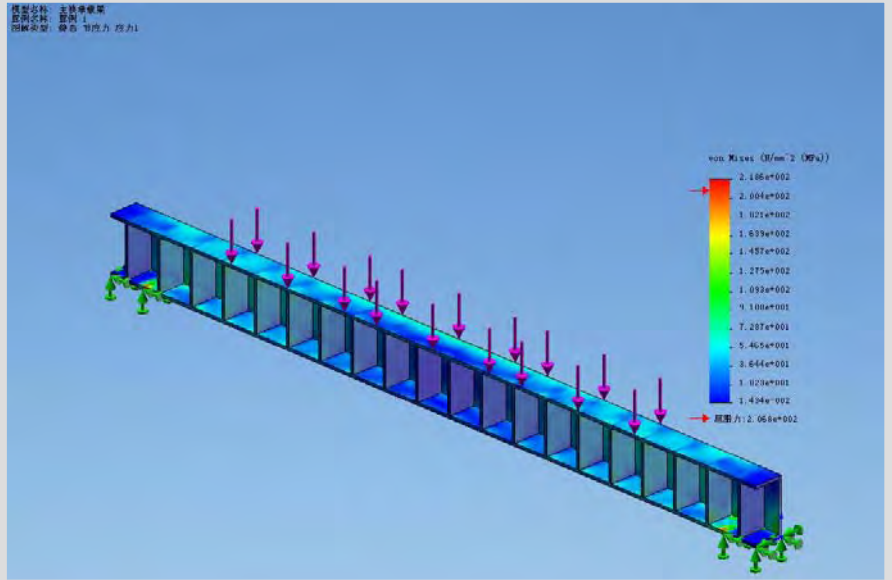

Quality Control

■ Process and Project Control

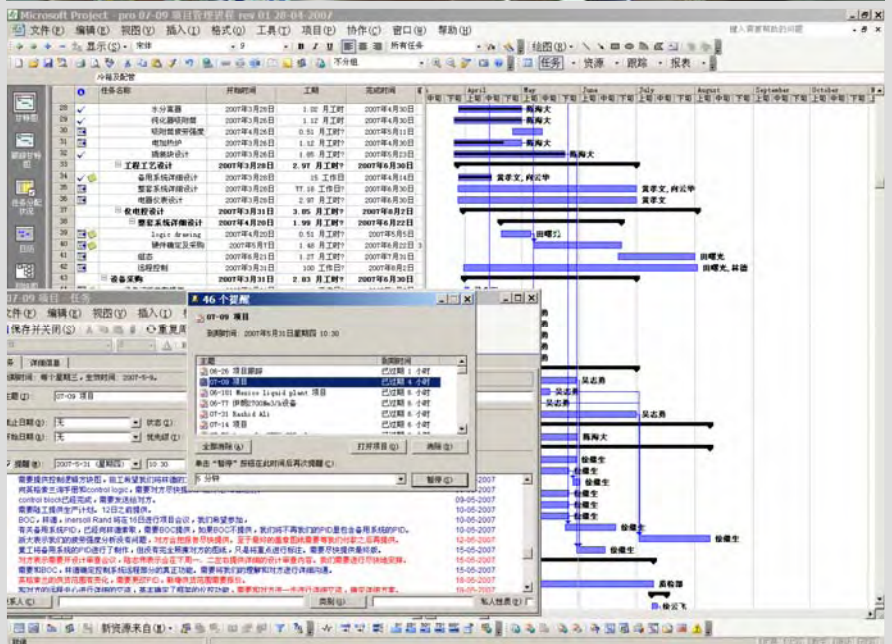

Quality Control

■ Welding inspection



Products

■ Layout



Products

■ Cases with Argon

- GOX 6000, GAN 6000, LAr 200 plant in Shandong, China.
- GOX 3000, GAN 3000, LAr 100 Plant in Inner Mongolia, China.
- GOX 2800, LOX 200, GAN 2000, LAr 110 for Iraq
- LOX 3500, LIN 1000, LAr 120 for Fujian, China



- LOX 3000, LIN 3000, LAr 100 in Ningbo China
- LOX 3000, LIN 3000, LAr 100 Plant in Hangzhou, China.



- GOX 1200 GAN 2000 LAr 30 two sets for Kazakhstan



Products



■ Medium size plants in 2006

Medium size projects in year of 2006		
No.	Project	Specification
1	ONLA-6000/6000/200	Gaseous ASP
2	LOLNLA-3000/3000/100	Full liquid plant
3	OLONLA-2800/200/2000/110	Gaseous ASP
4	LN-6400	Nitrogen liquefaction plant
5	LN-2000	Nitrogen liquefaction plant
6	OLON-2000/100/4000	Gaseous ASP
7	ON-1500/3000	Gaseous ASP
8	ON-1500/3000	Gaseous ASP
9	NLN-3600/200	Nitrogen plant
10	ONLA-1200/1200/30	Gaseous ASP
11	ON-1200/2000	Gaseous ASP
12	ON-1200/2000	Gaseous ASP
13	ON-1000/2000	Gaseous ASP

Further more, we have manufactured and delivered more than 40 sets of all kind small size ASP in year of 2006.

■ Oversea market

- Jordan
- Iraq
- Iran
- Kazakstan
- Myanmar
- Vietnam
- Egypt
- Pakistan
- Angola

.....

Products

■ In China's domestic market



Note: Each yellow point means one city which has Fortune's plants. It is counted from 2000 to 2006.



Products

■ Liquefaction plant cases



100TPD LNG Plant



2000Nm³/h N₂ Liquefaction plant



Products



■ Medium size GOX plants



Products

■ Nitrogen plant – cases



Cooperation with Linde



**COOPERATION WITH LINDE
GROUP, MANUFACTURING AIR
SEPARATION PLANTS FOR ITS
BRANCH: BOC & LINDE GAS.**



Customers



Customer from SOL



Fortune With Denieli



With LINDE GAS & BOC, Visiting the new workshop.



Customers



Customers from Poland



Customer from USA

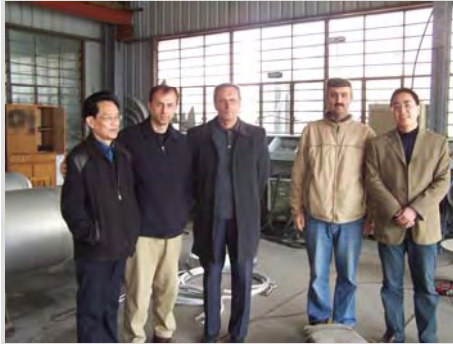

Customers from Iran



Customers from Italy



Customers from Jordan



Customers In Vietnam



Customers from Iraq



Customers from Africa



Customers from India



.....

Contact Us



FORTUNE

HANGZHOU FORTUNE
ENGINEERING CO., LTD.

**Add: #159, Donghu Rd.(North), Linping,
Hangzhou, Zhejiang, China.**

Zip code:311100

Tel: +86-571-86130862

Fax: +86-571-89181171

Http: www.fortune-gas.com

Email: info@fortune-gas.com

